



INSTALLATION INSTRUCTIONS

APPLICATION: 1999- 01 CHEVROLET SILVERADO
1500 SERIES 2/4 WHEEL DRIVE

AUTOMOTIVE PRODUCTS, INC.

SPORTSMAN
ASSEMBLY

40-0185

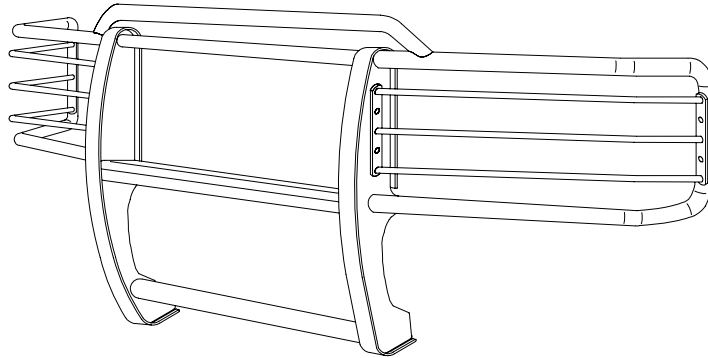

QTY	PARTS KIT CONTENTS DESCRIPTION	TOOLS REQUIRED
1	SPORTSMAN ASSEMBLY WITH LIGHT GUARDS	9/16" WRENCH
2	STIFFENER BRACKET	9/16" SOCKET
2	TOP BRACKET	3/4" SOCKET
2	BOTTOM BRACKET	18MM SOCKET
4	3/8 -16 X 1.25" LG. HEX HEAD BOLT	10MM SOCKET
8	3/8" FLAT WASHER, ZINC PLATED	RATCHET
4	3/8" LOCK WASHER, ZINC PLATED	TORQUE WRENCH
4	3/8 -16 HEX NUT, ZINC PLATED	PHILLIPS SCREWDRIVER
2	BOLT PLATE	SMALL FLAT SCREWDRIVER
2	M12 X 90 MM FULLY THREADED HEX HEAD BOLTS	19MM SOCKET
4	1/2" FLAT WASHERS	SOCKET EXTENSION
4	1/2" LOCK WASHERS	
2	SPACER TUBE	
2	1/2 -13 HEX NUT	

- STEP 1. Remove the contents from the box and check for any damage. Verify all parts against the parts list.
- STEP 2. Read and understand instructions completely before beginning installation.
- STEP 3. Remove plastic shroud above grille by removing the seven pin retainers. Pull center pin up with small flat screwdriver. **See Figure 1.**
- STEP 4. Remove grille from truck by removing 6mm bolt from top of grille. Turn the four retainers 1/4 turn counter-clockwise with Phillips screwdriver. Pull on outer edge of grille by applying firm pressure away from the fender, repeat on the opposite side. Carefully remove grille from vehicle. **See Figures 1.**
- STEP 5. To install top brackets, remove both 12mm factory bumper bolts from top of frame (located behind the top side of bumper), and remove two 6mm bolts in radiator support frame (located just above bumper bolts). On each side, replace with spacer tube, top mount bracket, stiffener bracket, 1/2" flat washer, 1/2" lock washer, and 12mm x 1.75 x 90mm bolt, finger tighten 12mm and 6mm bolts. **See Figures 2 and 3.**
- Note:** Top of stiffener bracket (long slotted end) should be installed beneath lower transmission cooler support bar.
- STEP 6. To install bottom brackets, remove 12mm bolts from bottom side of frame (4X4 only). Position bottom

bracket as shown and reinstall 12mm bolt finger tight, for 2WD use the bolt plate provided. **See Figure 3.**

- STEP 7. Raise the Sportsman up to the brackets and attach using 3/8" hardware and hand tighten. Adjust Sportsman to center of truck and torque all fasteners at the frame locations only to: 1/2" fasteners = 65 FT. LBS; 12mm fasteners = 60 FT. LBS; 6mm fasteners = 10 FT. LBS.
- STEP 8. Remove Sportsman from brackets and re-install vehicle grille and plastic shroud in the opposite order of removal.

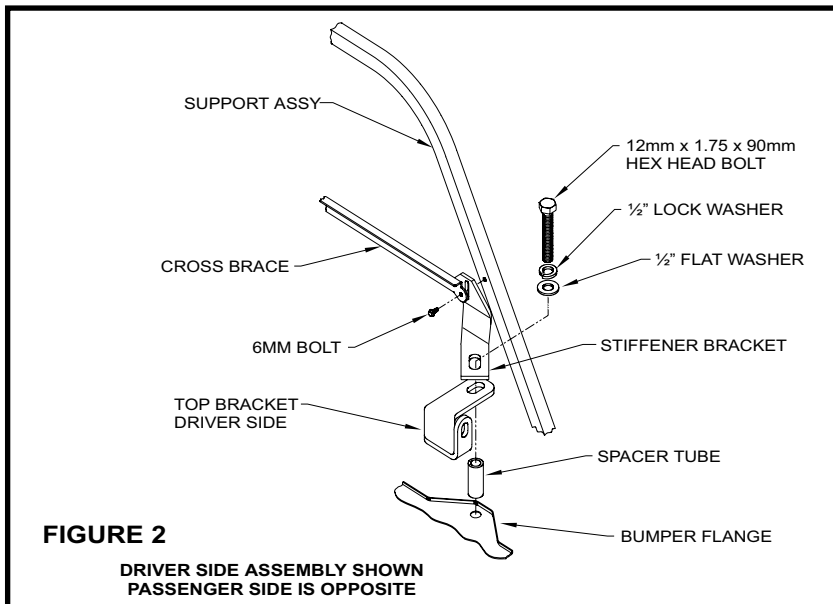
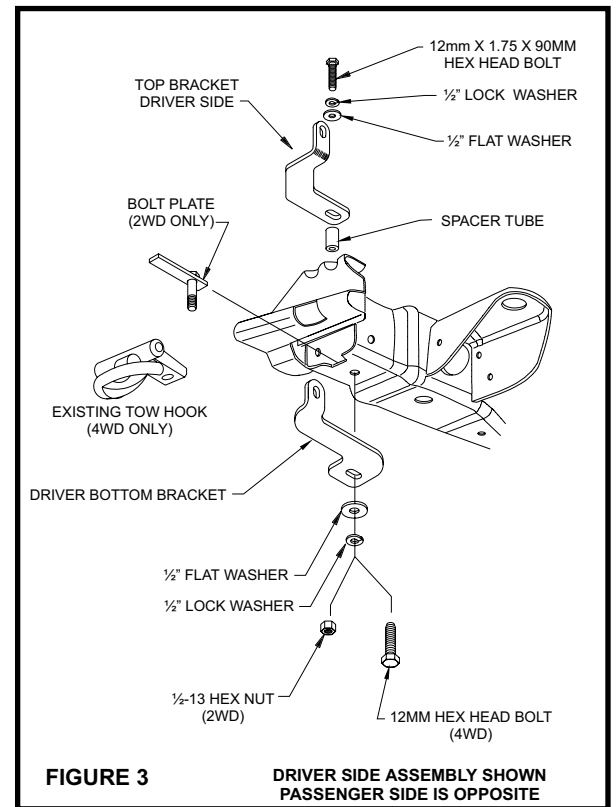
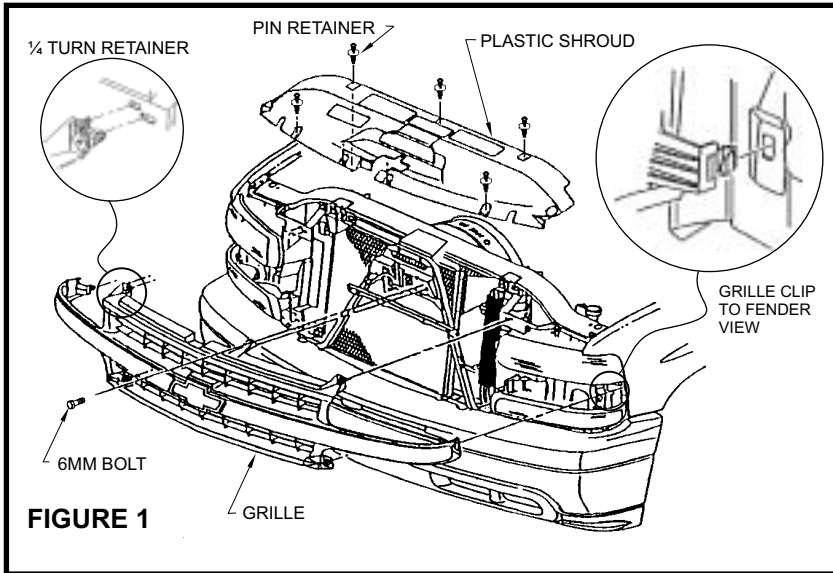

Finish protection - Westin products have a high quality finish that must be cared for like any other exposed finish on the vehicle. Protect the finish with a non-abrasive automotive wax (pure carnauba, for example) on a regular basis. The use of cleaner wax or any compound which contains an abrasive is detrimental, as the compound scratches the finish and opens it to corrosion.